

# ERV-ENERGY RECOVERY



## XEM External Mount Unit

### XEM2400P3 Technical Data

#### Technical Specifications

##### Nominal Airflow

Supply Air (l/sec)	1900 - 2400
Exhaust Air (l/sec)	1900 - 2400
Return Air (l/sec)	1900 - 2400
Fresh Air (l/sec)	1900 - 2400

##### Supply Fan

Fan Type	EC Plug Fan
Motor Power (Watts)	4450
External Static (Pa)	250
Fan Diameter	450
Number of Fans	1

##### Exhaust Fan

Fan Type	EC Plug Fan
Motor Power (Watts)	4450
External Static (Pa)	250
Fan Diameter	450
Number of Fans	1

##### Electrical

\*Cable sized to maximum FLA.  
Data presented for airflow at 2400 L/s

Operating Supply Fan (A)	3.7 - 3.7 - 3.7
Operating Exhaust Fan (A)	3.7 - 3.7 - 3.7
Operating Run Current (A)	7.4 - 7.4 - 7.4
Maximum Full Load (A)	13.6 - 13.6 - 13.6
Volt/Phase	415V/3ph

##### Controls

0-10V DC (Fan Control)	Included
24V AC Fan Enable Relay	Included
Fan Fault Signal 24V Output	Included
Fan Control Status	Available
Switchboard	Yes
Circuit Breakers	Yes

##### Heat Exchanger

\*Rated at standard conditions of 35.5° db/24.0° wb

Enthalpy Media	Standard
Sensible Media	Available
Face Velocity (m/sec)	1.9
Pressure Drop (Pa)	155.6
Kw Recovered (Cooling)*	36.4
Kw Recovered (Heating)*	42.2

##### Cabinet Construction

Casing	50mm Panel
Finish	Surf Mist Colourbond
Insulation Value	R2.0
Side Access Panels	Included

##### Options

Chilled Water/Hot Water Coil	Available (Model XEC2400)
Economy Cycle	Available (Model XEM2400P3-E)
Return Air Bypass	Available

# ERV-ENERGY RECOVERY

## XEM External Mount Unit – XEM2400P3 Technical Data

### Technical Drawings – XEM2400P3

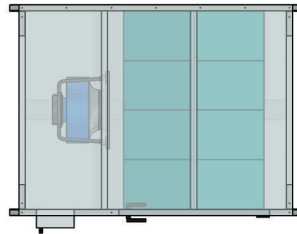

PLAN VIEW

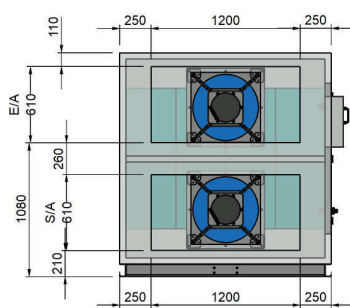
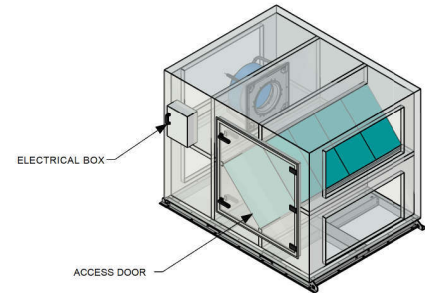

E/A & S/A SPIGOTS

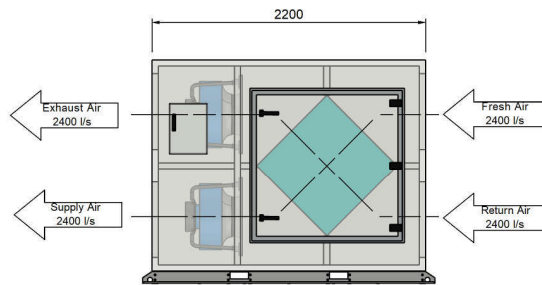

ELEVATION VIEW - ACCESS PANEL SIDE

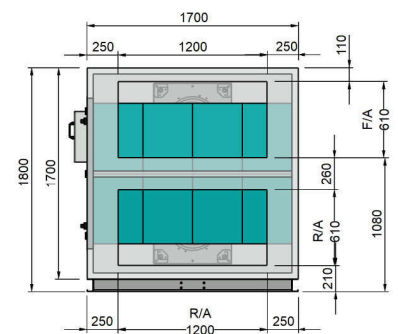

F/A & R/A SPIGOTS

Dimension	
Height (mm)	1800
Width (mm)	1700
Length (mm)	2200
Weight (Kg)	790
Access Clearance (mm)	1200 (Fan & Media Access)
Access Clearance (mm)	900 (Electrical Controls)

Duct Sizes	
Exhaust Air (mm)	1200 x 610
Return Air (mm)	1200 x 610
Supply Air (mm)	1200 x 610
Fresh Air (mm)	1200 x 610

### Fan Performance Data

\*Duty point - 2400 L/s at 600 Pa Total Static Pressure (250Pa External Static Pressure)

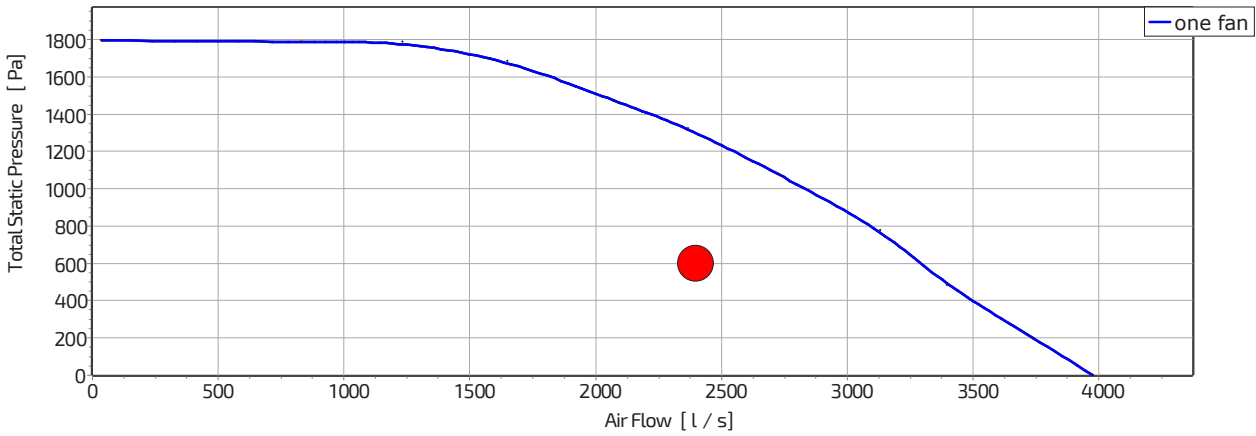

### Sound Power Levels

\*Sound power levels at 600 Pa Total Static Pressure and 2400 L/s Total Air Volume

Inlet Rating dB (A)		Outlet Rating dB (A)	
63 Hz	45.5	63 Hz	48.0
125 Hz	62.7	125 Hz	64.1
250 Hz	71.2	250 Hz	70.4
500 Hz	73.6	500 Hz	77.1
1 K Hz	73.7	1K Hz	81.9
2K Hz	75.3	2K Hz	82.5
4K Hz	78.6	4K Hz	80.8
8K Hz	73.6	8K Hz	75.8
LwA	82.8	LwA	87.4

### Wiring Diagram

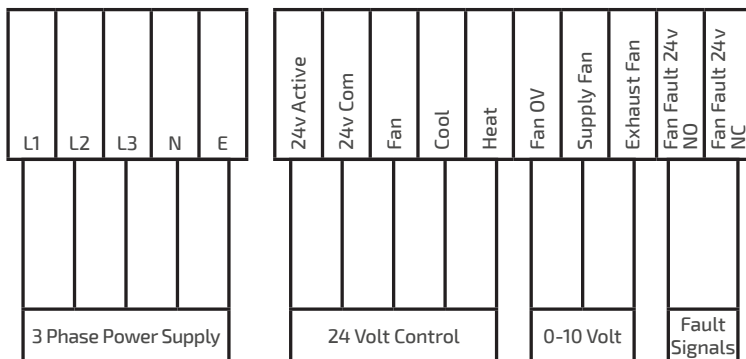

#### STANDARD INCLUSIONS

Fan Speed Controller  
 0-10v DC - BMS Connection, **OR**  
 24v AC - Fan Speed Control via Pots

Circuit Breakers

