

ERV-PAC Packaged Airconditioning



XEP Packaged Airconditioning Unit

XEP1200P3 Technical Data

Technical Specifications

Nominal Airflow

Supply Air (l/sec)	1000 - 1200
Return Air (l/sec)	1000 - 1200
Fresh Air (l/sec)	1000 - 1200
Condensor Air (l/sec)	960
Exhaust Air (l/sec)	2160

Supply Fan

Fan Type	EC Plug Fan
Motor Power (Watts)	1900
External Static (Pa)	250
Fan Diameter	355
Number of Fans	1

Exhaust Fan

Fan Type	EC Plug Fan
Motor Power (Watts)	1900
External Static (Pa)	250
Fan Diameter	355
Number of Fans	2

Electrical

*Max FLA to be used to size supply cables and relevant safety devices

Compressor Type	Fixed Speed	Inverter
Total Run Current (A)	21.4 - 21.4 - 21.4	19.6 - 19.6 - 19.6
Maximum Full Load (A)	35.4 - 35.4 - 35.4	38.2 - 38.2 - 38.2
Power Supply (V/Ph/Hz)	415/3/50	415/3/50

Controls

0-10V DC (Fan Control)	Included
24V AC Fan Enable Relay	Included
Fan Fault Signal 24V Output	Included
Fan Control Status	Available
Switchboard	Yes
Circuit Breakers	Yes

Heat Exchanger

*Rated at standard conditions of 35.5° db/24.0° wb

	Enthalpy	Sensible
Corrosion Resistant Media	Not Available	Available
Face Velocity (m/sec)	1.9	1.7
Pressure Drop (Pa)	131	47
Kw Recovered (Cooling)*	19.5	9
Kw Recovered (Heating)*	23.3	11

Cabinet Construction

Casing	50mm Insulated Panel
Finish	Surf Mist Colourbond
Insulation Value	R2.0
Side Access Panels	Included

Design Temperatures

Ambient (DB/WB) Summer	35°C/24°C
Return Air (DB/WB) Summer	24°C/17°C
Ambient Winter	7°C
Return Air Winter	21°C

Coil Selection

Indoor Coil FL x FH (mm)	1150 x 482
Face Velocity (m/sec)	2.2
Outdoor Coil FL x FH (mm)	1150 x 711
Face Velocity (m/sec)	2.6
Anti-Corrosion Coil Coating	Included
Drain Tray	Stainless Steel

Refrigeration

*At standard design temperatures

Heating Capacity (kW)*	27
Cooling Capacity (kW)*	27
Fixed Speed Compressor	Standard - x1 - R407C
Inverter Compressor	Available - x1 - R410A
Expansion Device	TX Biflow Valves
Head Pressure Control	Included

Options

Economy Cycle	Available (XEP1200P3-E)
Return Air Bypass Damper	Available

Technical Drawings – XEP1200P3

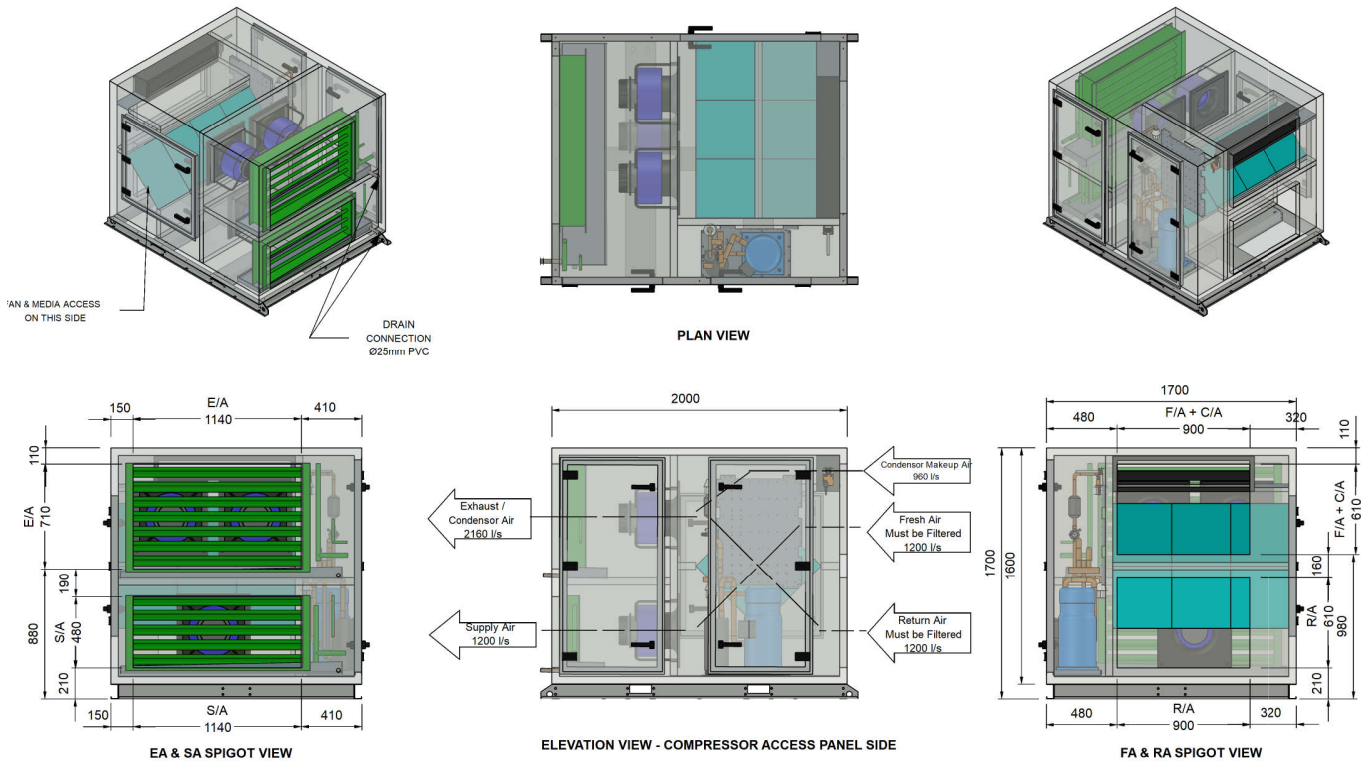

Dimension

Height (mm)	1700
Width (mm)	1700
Length (mm)	2000
Weight (kg)	720
Access Clearance (mm)	1200 (Fan & Media Access)
Access Clearance (mm)	1200 (Electrical Controls)

Duct Sizes

Supply Air (mm)	1140 x 480
Return Air (mm)	900 x 610
Fresh Air/Condensor Air Inlet	900 x 610
Exhaust/Condensor Air	1140 x 710
Recommended min F/A Filter Size	915 x 610

Compressor Performance Data

Compressor Capacity (KW) – Cooling

Return Air Temperatures	Outdoor Coil Entering Air Temperature (E.A.T) °C db											
	23		27		31		35		39		43	
24°C/17°C db/wb	Total	Sens.	Total	Sens.	Total	Sens.	Total	Sens.	Total	Sens.	Total	Sens.
	29.2	23.1	28.6	23.1	28.1	22.9	27.0	22.2	25.1	21.1	23.1	16.2

Compressor Capacity (KW) – Heating

Return Air Temperatures	Outdoor Coil Entering Air Temperature (E.A.T) °C db					
	-1	1	3	5	7	9
22°C	20.8	22.1	23.5	25.4	27.0	28.1

For winter operation the air on to the DX coil must be a minimum of 15°C. If this cannot be achieved, we recommend using a EDH or hot water coil to maintain the correct temperature onto the DX coil.

Fan Performance Data

*Duty point - 1200 L/s at 700 Pa Total Static Pressure (250Pa External Static Pressure)

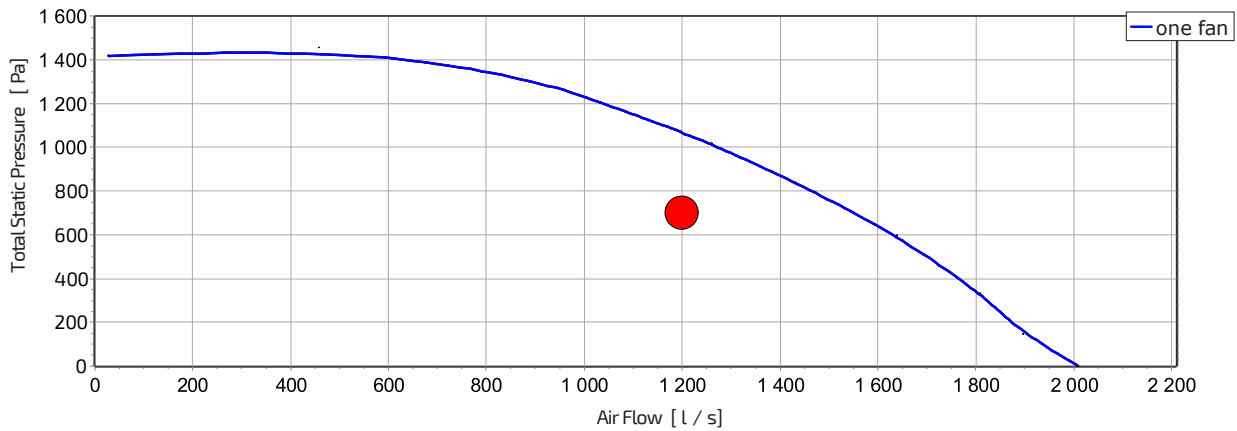

Sound Power Levels

*Sound power levels at 700 Pa Total Static Pressure and 1200 L/s Total Air Volume

Inlet Rating dB		Outlet Rating dB	
63 Hz	36.5	63 Hz	39.3
125 Hz	51.5	125 Hz	52.1
250 Hz	67.7	250 Hz	65.4
500 Hz	69.1	500 Hz	72.0
1K Hz	70.5	1K Hz	78.0
2K Hz	72.7	2K Hz	78.0
4K Hz	73.5	4K Hz	78.3
8K Hz	64.6	8K Hz	69.4
LwA	78.3	LwA	83.5

Wiring Diagram

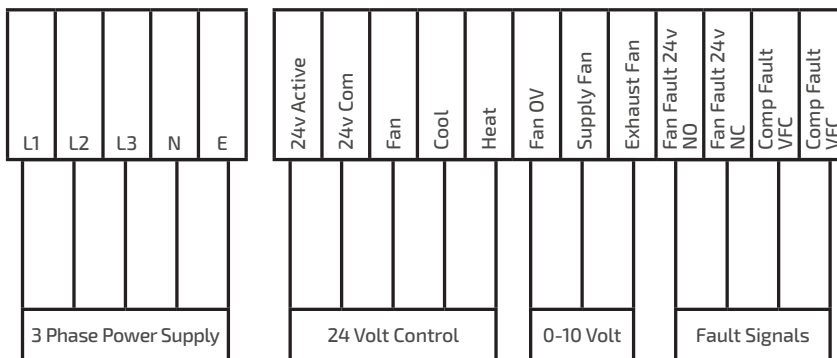

STANDARD INCLUSIONS

- Fan Speed Controller
0-10v DC - BMS Connection, **OR**
24v AC - Fan Speed Control via Pots
- Circuit Breakers
- Time Delay Relay
- Phase Fail Relay
- Reversing Valve
- High Pressure Cutout
- Low Pressure Cutout
- Compressor Overload

OPTIONS

- Compressor Sump Heater
- Current Sensing Relay

