

ERV-ENERGY RECOVERY



XEM External Mount Unit

XEM7500P3 Technical Data

Technical Specifications

Nominal Airflow

Supply Air (l/sec)	6500 - 7500
Exhaust Air (l/sec)	6500 - 7500
Return Air (l/sec)	6500 - 7500
Fresh Air (l/sec)	6500 - 7500

Supply Fan

Fan Type	EC Plug Fan
Motor Power (Watts)	4450
External Static (Pa)	250
Fan Diameter	450
Number of Fans	3

Exhaust Fan

Fan Type	EC Plug Fan
Motor Power (Watts)	4450
External Static (Pa)	250
Fan Diameter	450
Number of Fans	3

Electrical

*Max FLA to be used to size supply cables and relevant safety devices

Total Run Current (A)	23.6 - 23.6 - 23.6
Maximum Full Load (A)	40.8 - 40.8 - 40.8
Power Supply (V/Ph/Hz)	415/3/50

Controls

0-10V DC (Fan Control)	Included
24V AC Fan Enable Relay	Included
Fan Fault Signal 24V Output	Included
Fan Control Status	Available
Switchboard	Yes
Circuit Breakers	Yes

Heat Exchanger

*Rated at standard conditions of 35.5° db/24.0° wb

	Enthalpy	Sensible
Corrosion Resistant Media	Not Available	Available
Face Velocity (m/sec)	2.08	1.9
Pressure Drop (Pa)	207	107.4
Kw Recovered (Cooling)*	126	69
Kw Recovered (Heating)*	149	83

Cabinet Construction

Casing	50mm Panel
Finish	Surf Mist Colourbond
Insulation Value	R2.0
Side Access Panels	Included

Options

Chilled Water/Hot Water Coil	Available (Model XEC7500)
Return Air Bypass	Available

ERV-ENERGY RECOVERY

XEM External Mount Unit – XEM7500P3 Technical Data

Technical Drawings – XEM7500P3

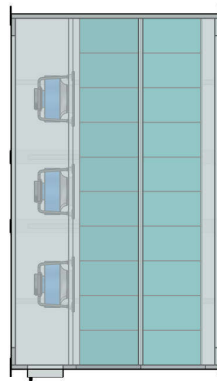

PLAN VIEW

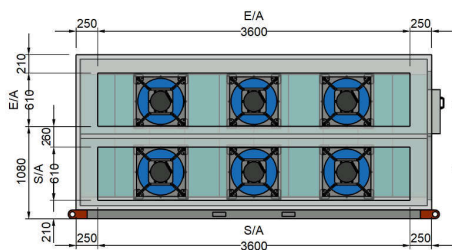
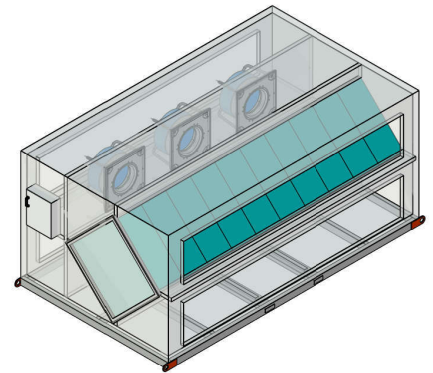

E/A & S/A SPIGOTS

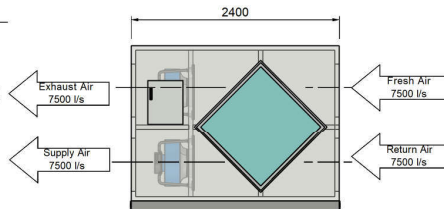

ELEVATION VIEW - ACCESS PANEL SIDE

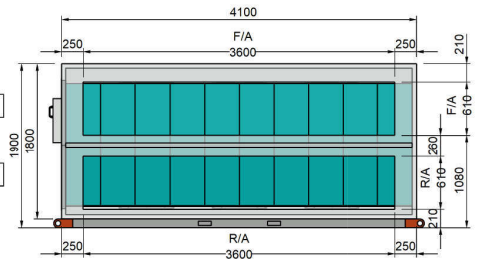

F/A & R/A SPIGOTS

Dimension	
Height (mm)	1900
Width (mm)	4100
Length (mm)	2400
Weight (Kg)	1660
Access Clearance (mm)	1200 (Fan & Media Access)
Access Clearance (mm)	900 (Electrical Controls)

Duct Sizes	
Exhaust Air (mm)	3600 x 610
Return Air (mm)	3600 x 610
Supply Air (mm)	3600 x 610
Fresh Air (mm)	3600 x 610

Fan Performance Data

*Duty point - 7500 L/s at 600 Pa Total Static Pressure (250Pa External Static Pressure)

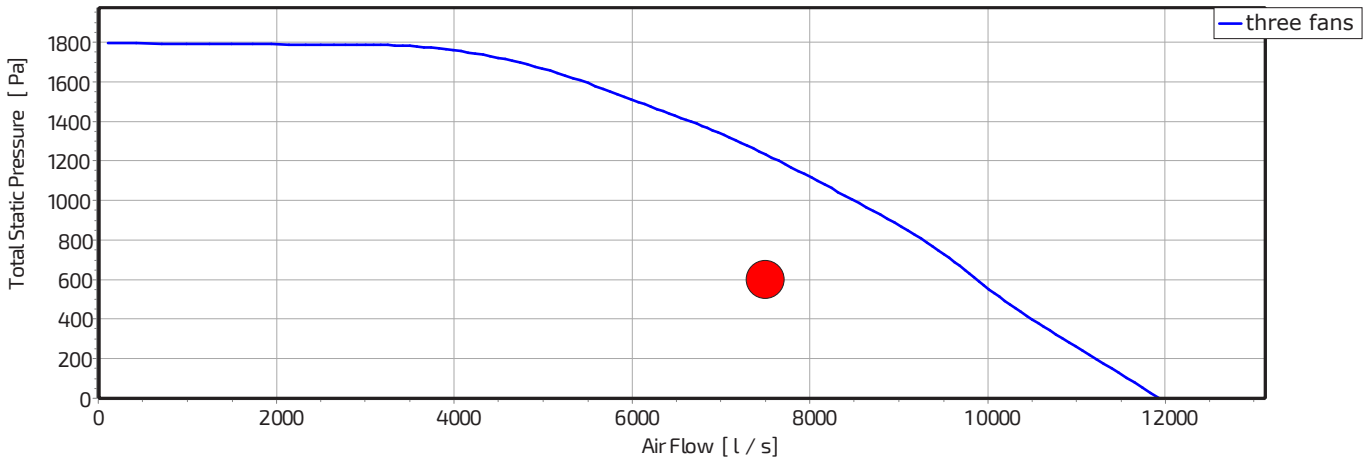

Sound Power Levels

*Sound power levels at 600 Pa Total Static Pressure and 7500 L/s Total Air Volume

Inlet Rating dB (A)		Outlet Rating dB (A)	
63 Hz	50.3	63 Hz	53.1
125 Hz	67.8	125 Hz	69.1
250 Hz	76.9	250 Hz	76.0
500 Hz	79.6	500 Hz	82.9
1 K Hz	79.3	1K Hz	87.6
2K Hz	81.0	2K Hz	88.3
4K Hz	84.0	4K Hz	86.2
8K Hz	80.6	8K Hz	82.1
LwA	88.6	LwA	93.2

Wiring Diagram

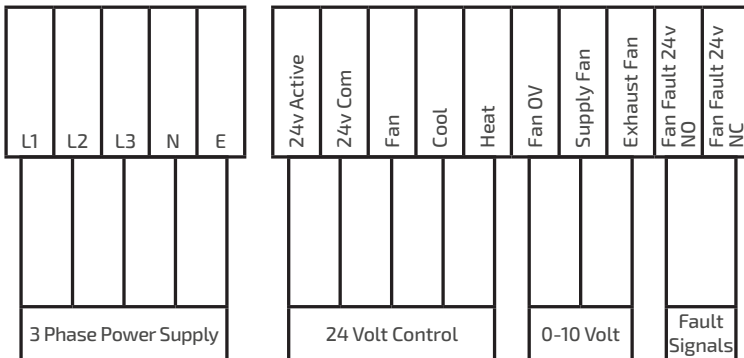

STANDARD INCLUSIONS

- Fan Speed Controller
- 0-10v DC - BMS Connection, **OR**
- 24v AC - Fan Speed Control via Pots
- Circuit Breakers

