

# ERV-ENERGY RECOVERY



## XEM External Mount Unit

### XEM5400P3 Technical Data

#### Technical Specifications

##### Nominal Airflow

Supply Air (l/sec)	4900 - 5400
Exhaust Air (l/sec)	4900 - 5400
Return Air (l/sec)	4900 - 5400
Fresh Air (l/sec)	4900 - 5400

##### Supply Fan

Fan Type	EC Plug Fan
Motor Power (Watts)	4450
External Static (Pa)	250
Fan Diameter	450
Number of Fans	2

##### Exhaust Fan

Fan Type	EC Plug Fan
Motor Power (Watts)	4450
External Static (Pa)	250
Fan Diameter	450
Number of Fans	2

##### Electrical

\*Max FLA to be used to size supply cables and relevant safety devices

Total Run Current (A)	17.6 - 17.6 - 17.6
Maximum Full Load (A)	27.2 - 27.2 - 27.2
Power Supply (V/Ph/Hz)	415/3/50

##### Controls

0-10V DC (Fan Control)	Included
24V AC Fan Enable Relay	Included
Fan Fault Signal 24V Output	Included
Fan Control Status	Available
Switchboard	Yes
Circuit Breakers	Yes

##### Heat Exchanger

\*Rated at standard conditions of 35.5° db/24.0° wb

	Enthalpy	Sensible
Corrosion Resistant Media	Not Available	Available
Face Velocity (m/sec)	2.1	1.9
Pressure Drop (Pa)	225	77.64
Kw Recovered (Cooling)*	90	45.6
Kw Recovered (Heating)*	105	55

##### Cabinet Construction

Casing	50mm Panel
Finish	Surf Mist Colourbond
Insulation Value	R2.0
Side Access Panels	Included

##### Options

Chilled Water/Hot Water Coil	Available (Model XEC5400)
Economy Cycle	Available (Model XEM5400P3-E)
Return Air Bypass	Available

# ERV-ENERGY RECOVERY

## XEM External Mount Unit – XEM5400P3 Technical Data



### Technical Drawings – XEM5400P3

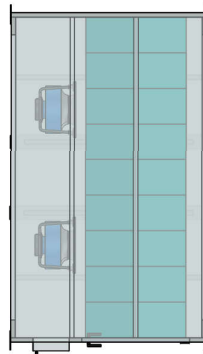

PLAN VIEW

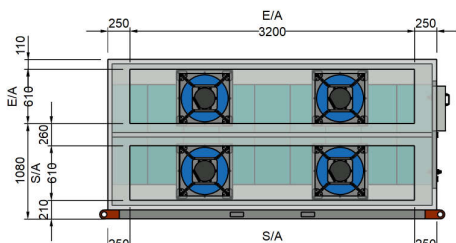
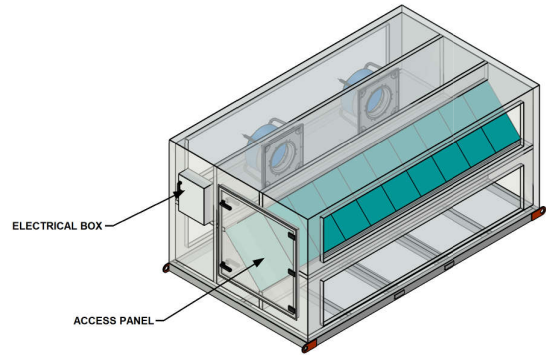

E/A & S/A SPIGOTS

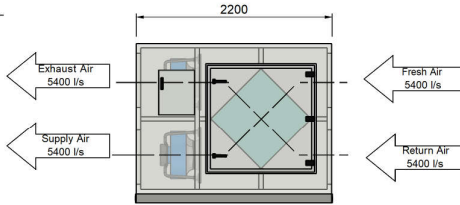

ELEVATION VIEW - ACCESS PANEL SIDE

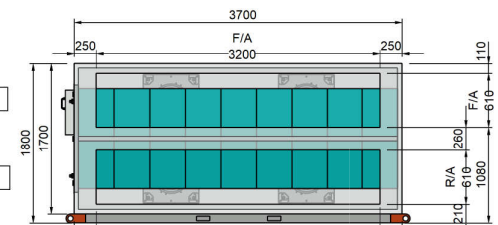

F/A & R/A SPIGOTS

#### Dimension

Height (mm)	1800
Width (mm)	3700
Length (mm)	2200
Weight (Kg)	1240
Access Clearance (mm)	1200 (Fan & Media Access)
Access Clearance (mm)	900 (Electrical Controls)

#### Duct Sizes

Exhaust Air (mm)	3200 x 610
Return Air (mm)	3200 x 610
Supply Air (mm)	3200 x 610
Fresh Air (mm)	3200 x 610

### Fan Performance Data

\*Duty point - 5400 L/s at 600 Pa Total Static Pressure (250Pa External Static Pressure)

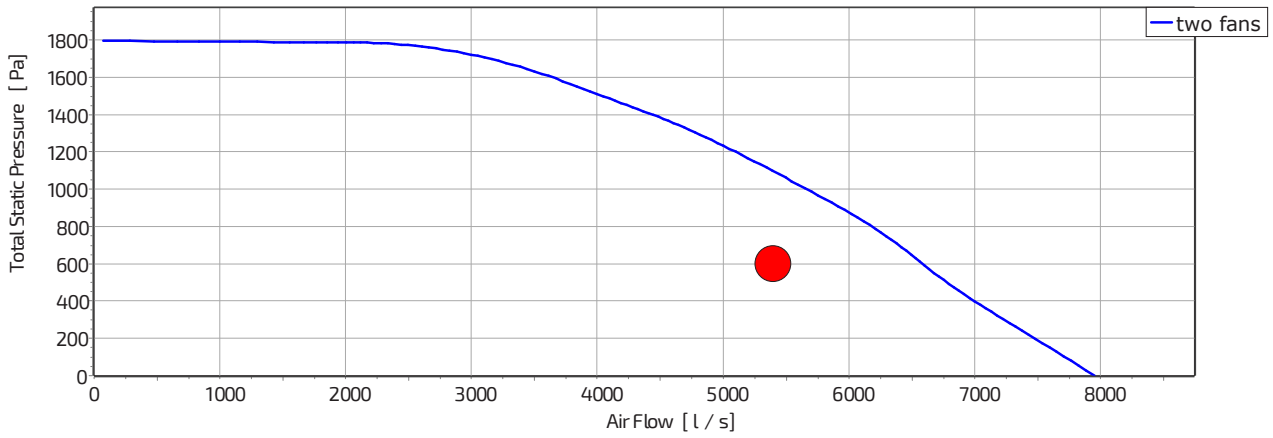

### Sound Power Levels

\*Sound power levels at 600 Pa Total Static Pressure and 5400 L/s Total Air Volume

Inlet Rating dB (A)		Outlet Rating dB (A)	
63 Hz	48.6	63 Hz	51.9
125 Hz	66.6	125 Hz	67.7
250 Hz	76.9	250 Hz	76.0
500 Hz	80.1	500 Hz	22.9
1 K Hz	79.1	1K Hz	87.5
2K Hz	81.1	2K Hz	88.5
4K Hz	82.9	4K Hz	85.5
8K Hz	82.9	8K Hz	83.2
LwA	88.8	LwA	93.2

### Wiring Diagram

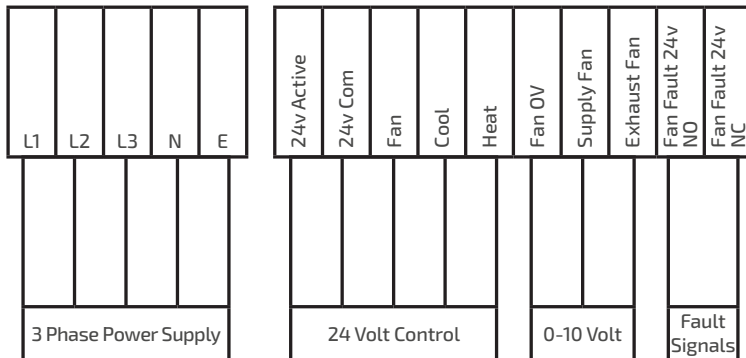

#### STANDARD INCLUSIONS

- Fan Speed Controller
- 0-10v DC - BMS Connection, **OR**
- 24v AC - Fan Speed Control via Pots
- Circuit Breakers

