

ERV-ENERGY RECOVERY



XEM External Mount Unit

XEM3600P3 Technical Data

Technical Specifications

Nominal Airflow

Supply Air (l/sec)	3100 - 3600
Exhaust Air (l/sec)	3100 - 3600
Return Air (l/sec)	3100 - 3600
Fresh Air (l/sec)	3100 - 3600

Supply Fan

Fan Type	EC Plug Fan
Motor Power (Watts)	4450
External Static (Pa)	250
Fan Diameter	450
Number of Fans	2

Exhaust Fan

Fan Type	EC Plug Fan
Motor Power (Watts)	4450
External Static (Pa)	250
Fan Diameter	450
Number of Fans	2

Electrical

*Max FLA to be used to size supply cables and relevant safety devices

Total Run Current (A)	10.6 - 10.6 - 10.6
Maximum Full Load (A)	27.2 - 27.2 - 27.2
Power Supply (V/Ph/Hz)	415/3/50

Controls

0-10V DC (Fan Control)	Included
24V AC Fan Enable Relay	Included
Fan Fault Signal 24V Output	Included
Fan Control Status	Available
Switchboard	Yes
Circuit Breakers	Yes

Heat Exchanger

*Rated at standard conditions of 35.5° db/24.0° wb

	Enthalpy	Sensible
Corrosion Resistant Media	Not Available	Available
Face Velocity (m/sec)	2.1	1.9
Pressure Drop (Pa)	225	77.6
Kw Recovered (Cooling)*	60	30.4
Kw Recovered (Heating)*	70	36.7

Cabinet Construction

Casing	50mm Panel
Finish	Surf Mist Colourbond
Insulation Value	R2.0
Side Access Panels	Included

Options

Chilled Water/Hot Water Coil	Available (Model XEC3600)
Economy Cycle	Available (Model XEM3600P3-E)
Return Air Bypass	Available

ERV-ENERGY RECOVERY

XEM External Mount Unit – XEM3600P3 Technical Data

Technical Drawings – XEM3600P3

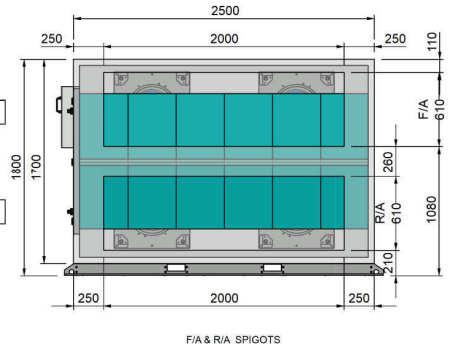
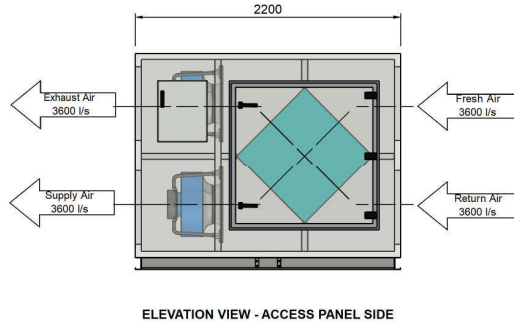
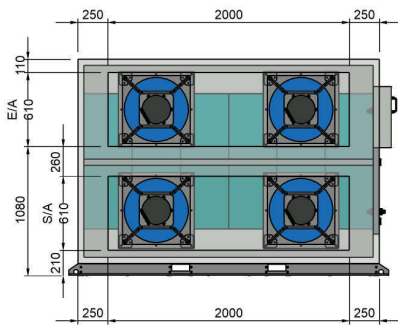
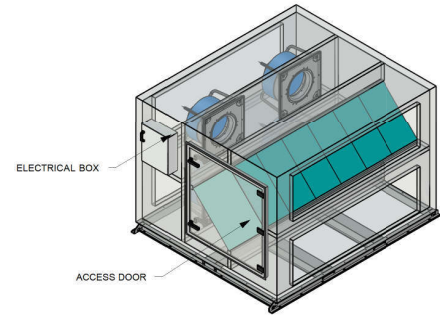
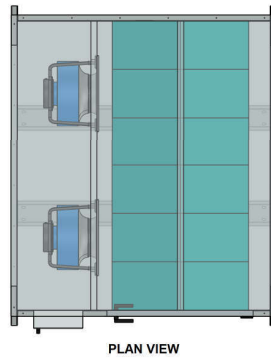

Dimension	
Height (mm)	1800
Width (mm)	2500
Length (mm)	2200
Weight (Kg)	935
Access Clearance (mm)	1200 (Fan & Media Access)
Access Clearance (mm)	900 (Electrical Controls)

Duct Sizes	
Exhaust Air (mm)	2000 x 610
Return Air (mm)	2000 x 610
Supply Air (mm)	2000 x 610
Fresh Air (mm)	2000 x 610

Fan Performance Data

*Duty point - 3600 L/s at 600 Pa Total Static Pressure (250Pa External Static Pressure)

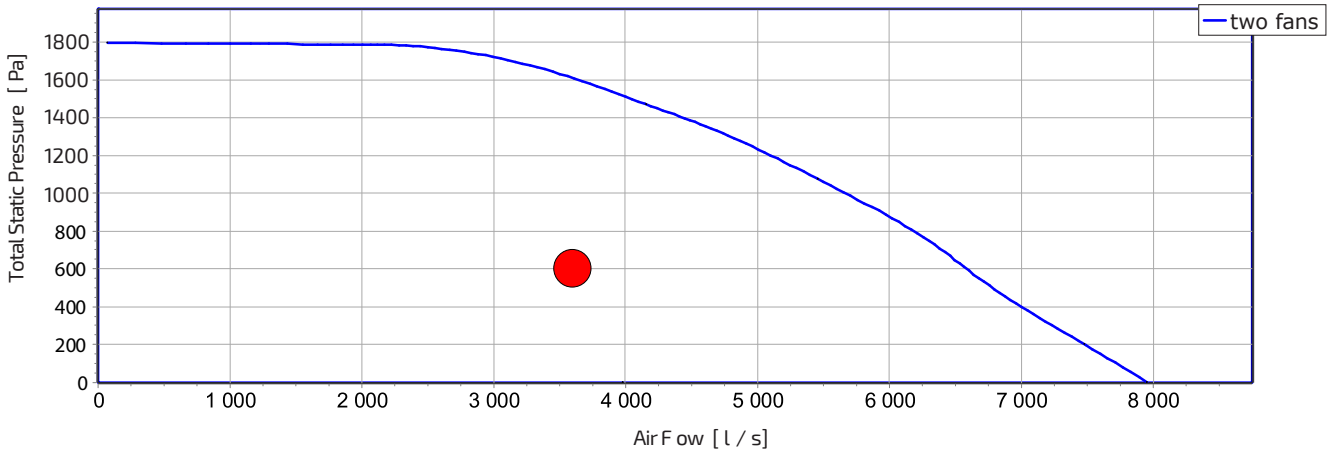

Sound Power Levels

*Sound power levels at 600 Pa Total Static Pressure and 3600 L/s Total Air Volume

Inlet Rating dB (A)		Outlet Rating dB (A)	
63 Hz	49.6	63 Hz	50.9
125 Hz	61.9	125 Hz	63.1
250 Hz	68.2	250 Hz	68.6
500 Hz	70.9	500 Hz	75.7
1 K Hz	72.8	1K Hz	80.7
2K Hz	73.2	2K Hz	79.9
4K Hz	74.5	4K Hz	78.2
8K Hz	64.4	8K Hz	69.8
LwA	79.6	LwA	85.3

Wiring Diagram

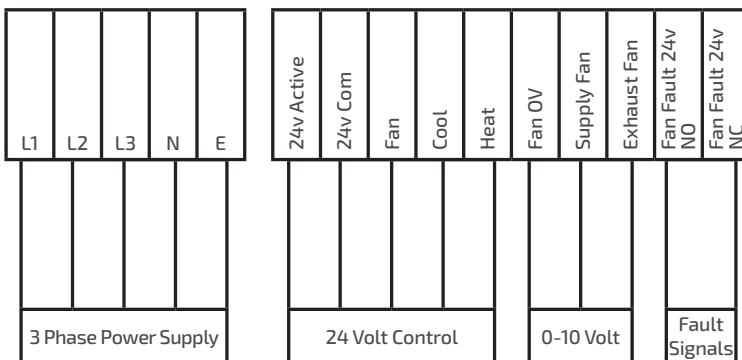

STANDARD INCLUSIONS

- Fan Speed Controller
- 0-10v DC - BMS Connection, **OR**
- 24v AC - Fan Speed Control via Pots
- Circuit Breakers

