

ERV-ENERGY RECOVERY



XEM External Mount Unit

XEM1200P3 Technical Data

Technical Specifications

Nominal Airflow

Supply Air (l/sec)	900 - 1200
Exhaust Air (l/sec)	900 - 1200
Return Air (l/sec)	900 - 1200
Fresh Air (l/sec)	900 - 1200

Supply Fan

Fan Type	EC Plug Fan
Motor Power (Watts)	1900
External Static (Pa)	250
Fan Diameter	355
Number of Fans	1

Exhaust Fan

Fan Type	EC Plug Fan
Motor Power (Watts)	1900
External Static (Pa)	250
Fan Diameter	355
Number of Fans	1

Electrical

*Max FLA to be used to size supply cables and relevant safety devices

Total Run Current (A)	3.6 - 3.6 - 3.6
Maximum Full Load (A)	6.6 - 6.6 - 6.6
Power Supply (V/Ph/Hz)	415/3/50

Controls

0-10V DC (Fan Control)	Included
24V AC Fan Enable Relay	Included
Fan Fault Signal 24V Output	Included
Fan Control Status	Available
Switchboard	Yes
Circuit Breakers	Yes

Heat Exchanger

*Rated at standard conditions of 35.5° db/24.0° wb

	Enthalpy	Sensible
Corrosion Resistant Media	Not Available	Available
Face Velocity (m/sec)	1.9	1.67
Pressure Drop (Pa)	105.1	46.9
Kw Recovered (Cooling)*	17.4	9
Kw Recovered (Heating)*	79.8	10.9

Cabinet Construction

Casing	50mm Panel
Finish	Surf Mist Colourbond
Insulation Value	R2.0
Side Access Panels	Included

Options

Chilled Water/Hot Water Coil	Available (Model XEC1200)
Economy Cycle	Available (Model XEM1200P3-E)
Return Air Bypass	Available

ERV-ENERGY RECOVERY

XEM External Mount Unit – XEM1200P3 Technical Data

Technical Drawings – XEM1200P3

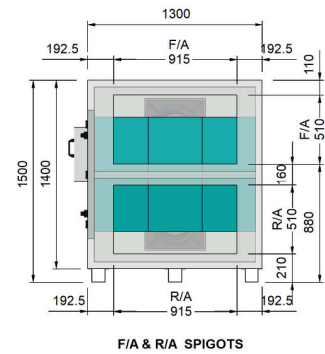
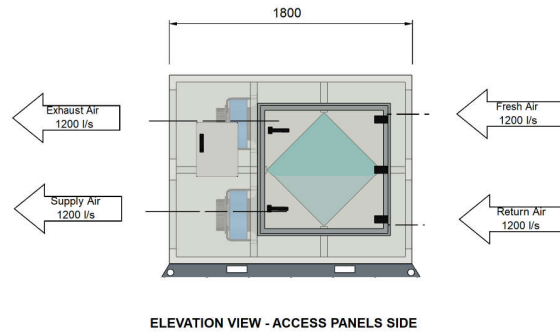
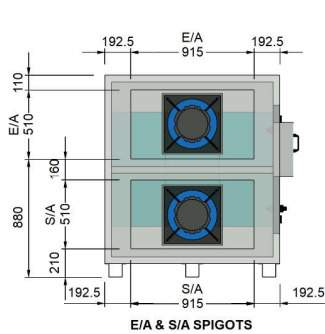
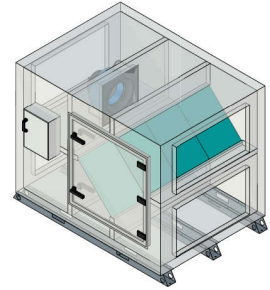
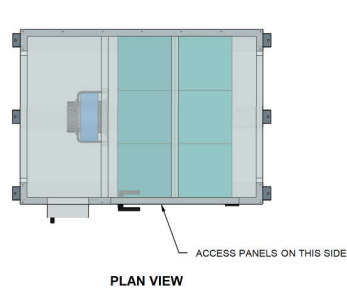

Dimension

Height (mm)	1500
Width (mm)	1300
Length (mm)	1800
Weight (Kg)	440
Access Clearance (mm)	1200 (Fan & Media Access)

Duct Sizes

Exhaust Air (mm)	915 x 510
Return Air (mm)	915 x 510
Supply Air (mm)	915 x 510
Fresh Air (mm)	915 x 510

Fan Performance Data

*Duty point - 1200 L/s at 600 Pa Total Static Pressure (250Pa External Static Pressure)

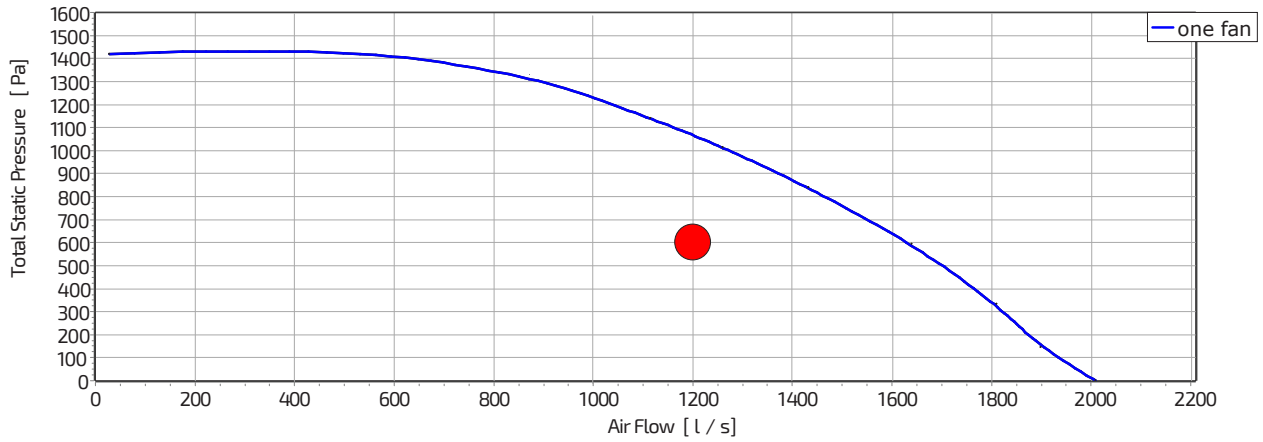

Sound Power Levels

*Sound power levels at 600 Pa Total Static Pressure and 1200 L/s Total Air Volume

Inlet Rating dB (A)		Outlet Rating dB (A)	
63 Hz	35.2	63 Hz	37.9
125 Hz	51.7	125 Hz	51.8
250 Hz	65.4	250 Hz	64.0
500 Hz	68.0	500 Hz	70.8
1 K Hz	70.2	1K Hz	77.4
2K Hz	72.0	2K Hz	77.3
4K Hz	73.4	4K Hz	77.9
8K Hz	63.4	8K Hz	68.2
LwA	77.8	LwA	82.8

Wiring Diagram

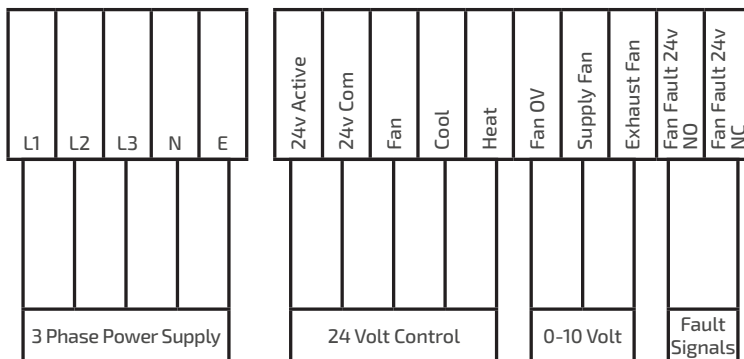

STANDARD INCLUSIONS

- Fan Speed Controller
- 0-10v DC - BMS Connection, **OR**
- 24v AC - Fan Speed Control via Pots
- Circuit Breakers

