

XCHANGE Energy Recovery

XCC-COMPACT MULTIFLOW ERV WITH COILS

XCC625P1 Technical Data



Technical Specifications

Nominal Airflow

Supply Air (l/sec)	625
Return Air (l/sec)	625

Supply Fan

Fan Type	EC Plug Fan
Fan Motor	EC External Rotor
Motor Power (Watts)	1000
External Static (Pa)	250
Fan Diameter	250
Motor Start	Soft Start
Control Input	0-10V DC
Motor Protection	Thermal Overload

Exhaust Fan

Fan Type	EC Plug Fan
Fan Motor	EC External Rotor
Motor Power (Watts)	1000
External Static (Pa)	250
Fan Diameter	250
Motor Start	Soft Start
Control Input	0-10V DC
Motor Protection	Thermal Overload

Electrical

Supply Fan (A)	2.9
Exhaust Fan (A)	2.9
Nominal Run Current (A)	5.8
Maximum Full Load (A)	10.2
Volt/Phase	240V/1ph
Connection	Lead & Plug

Controls

0-10V DC (Fan Control)	Included
24V AC Control	Included
Fan Fault	Only Available

Heat Exchanger

*Rated at standard conditions of 35.5° db/24.0° wb

Enthalpy Media	Standard (Model XCC625P1E)
Sensible Media	Available (Model XCC625P1S)
Corrosion Resistant Media	Available
Velocity (m/sec)	1.95
Pressure Drop (Pa)	162.6
Kw Recovered (Cooling)*	9.03
Kw Recovered (Heating)*	11.65

Cabinet Construction

Casing	Galvanised Metal
Insulation Thickness (mm)	15/25
Hanging Brackets	Included

Filters

Type	45mm V Form Panel - G4
Disposable / Washable	Disposable
Size L x W x D (mm)	395 x 395 x 50
Number of Filters	4

Options

Hot Water Coil	Available (Model XCC625P1-H)
Chilled Water Coil	Available (Model XCC625P1-C)
Hot & Chilled Water	Available (Model XCC625P1-CH)
DX Coil	Available (Model XCC625P1-D)
Remote Condenser	Available (Model XCC625-RC)
Internal Drain Tray	Available (Model XCC625P1-T)

XCHANGE Energy Recovery

XCC-COMPACT MULTIFLOW ERV WITH COILS

XCC625P1 Technical Data

Technical Drawings – XCC625P1

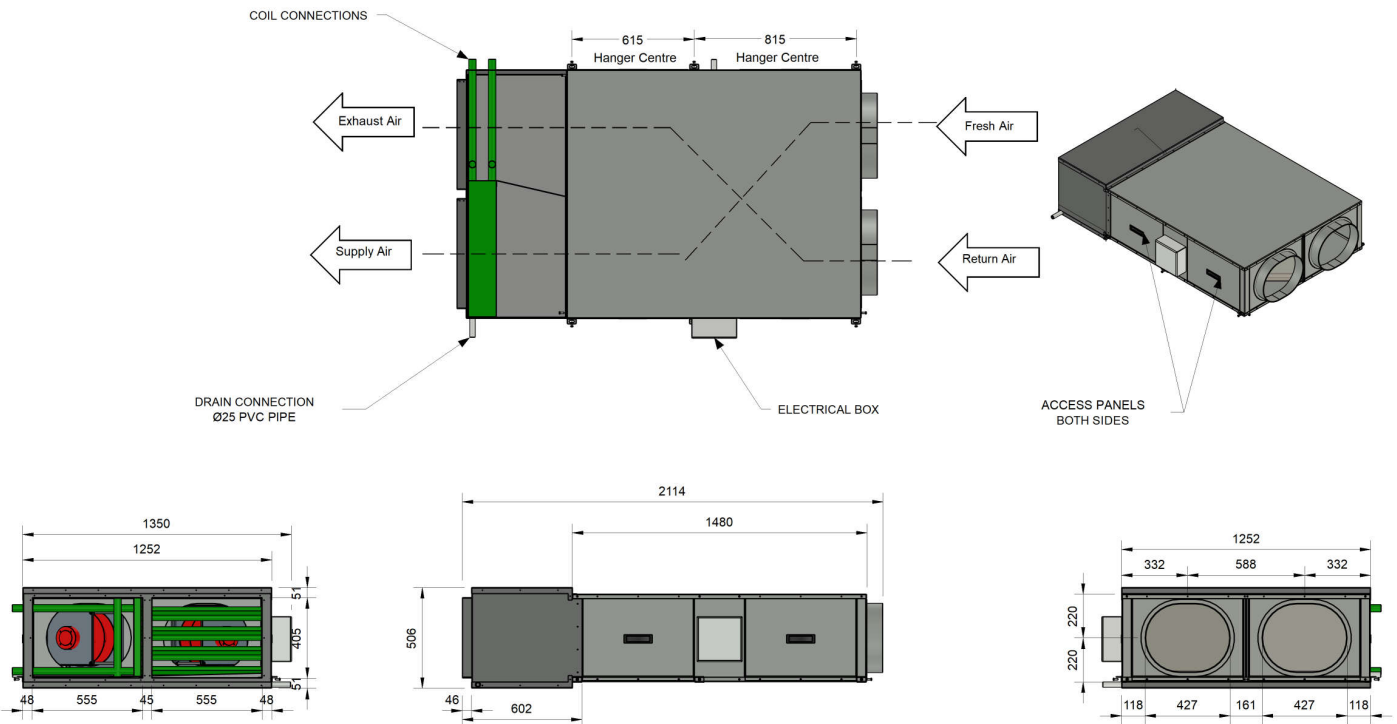

Notes:
 - All Panels are 1.2mm gal
 - Minimum 600mm Clearance Required from Access Panel

Dimensions

Height (mm)	506
Width (mm)	1252
Length (mm)	2114
Weight (kg) excl. coils	180
Access Clearance (mm)	600 (Controls & Filter Access)
Access Clearance (mm)	600 (Filter Access)

Duct Sizes

Exhaust Air (mm)	555 x 405
Return Air (mm)	400 Ø Oval
Supply Air (mm)	555 x 405
Fresh Air (mm)	400 Ø Oval

Wiring Diagram

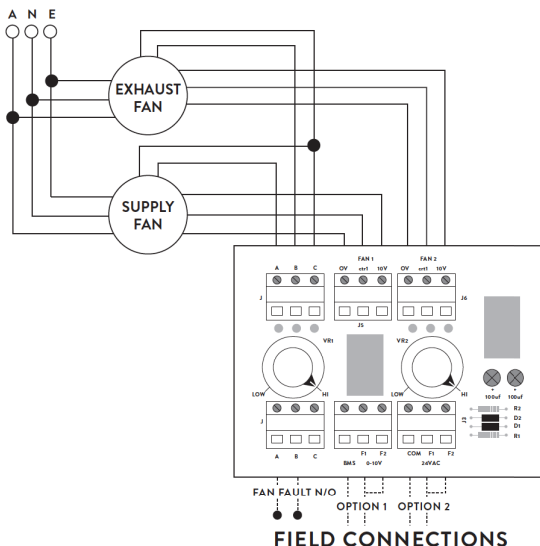

OPTION 1

0-10V DC CONTROL VIA CONNECTION TO BMS
 0V = STOP / 1.5V = START / 10V = FULL SPEED

OPTION 2

24V AC ENABLE REGULATE FAN SPEED VIA POTS
 EXTERNAL 24V PROVIDED BY OTHERS

Do not turn main power on/off to enable/disable the unit operation. This must be done through the control circuit.

FAN FAULT NOT AVAILABLE.

XCHANGE Energy Recovery

XCC-COMPACT MULTIFLOW ERV WITH COILS

XCC625P1 Technical Data

Fan Performance Data

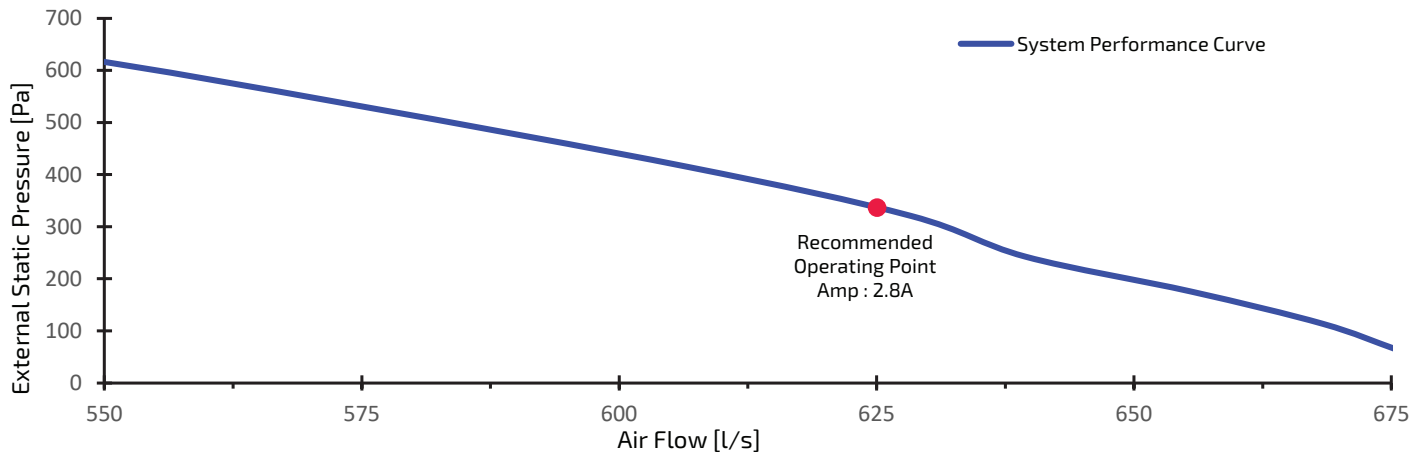

Sound Power Levels*

Inlet Rating dB		Outlet Rating dB	
63 Hz	72	63 Hz	74
125 Hz	65	125 Hz	67
250 Hz	72	250 Hz	74
500 Hz	81	500 Hz	83
1k Hz	73	1k Hz	75
2k Hz	66	2k Hz	68
4k Hz	56	4k Hz	58
8k Hz	65	8k Hz	67
LwA	83	LwA	85

* Sound Power Levels Recommended Operating Point.

Filter and Fan Access

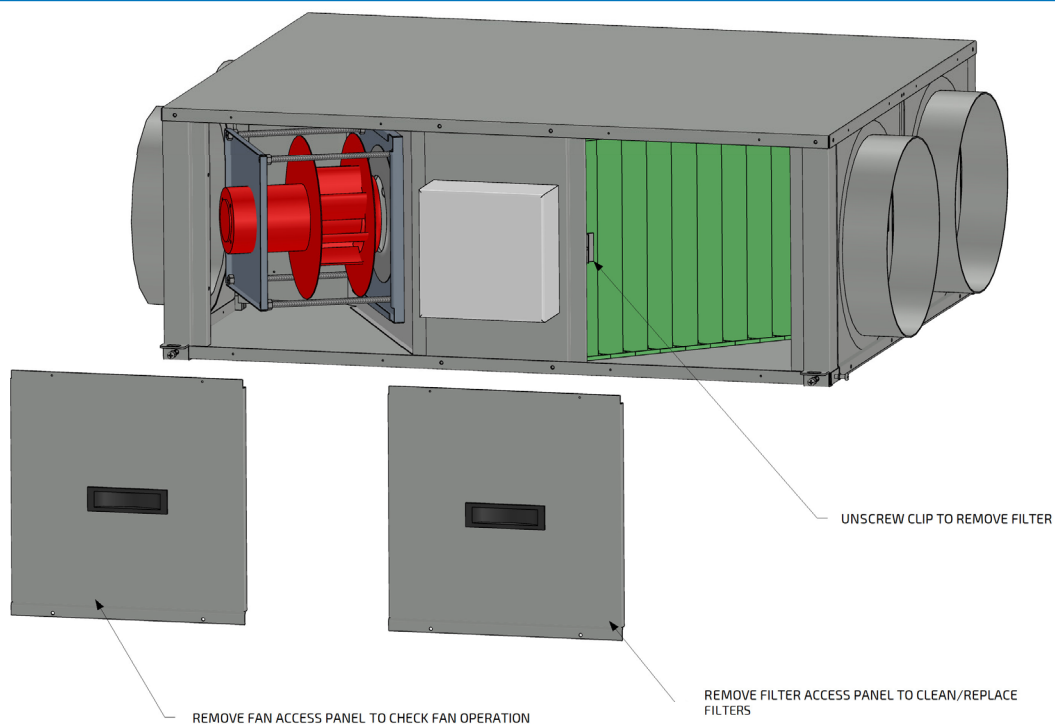

Ductwork Connections

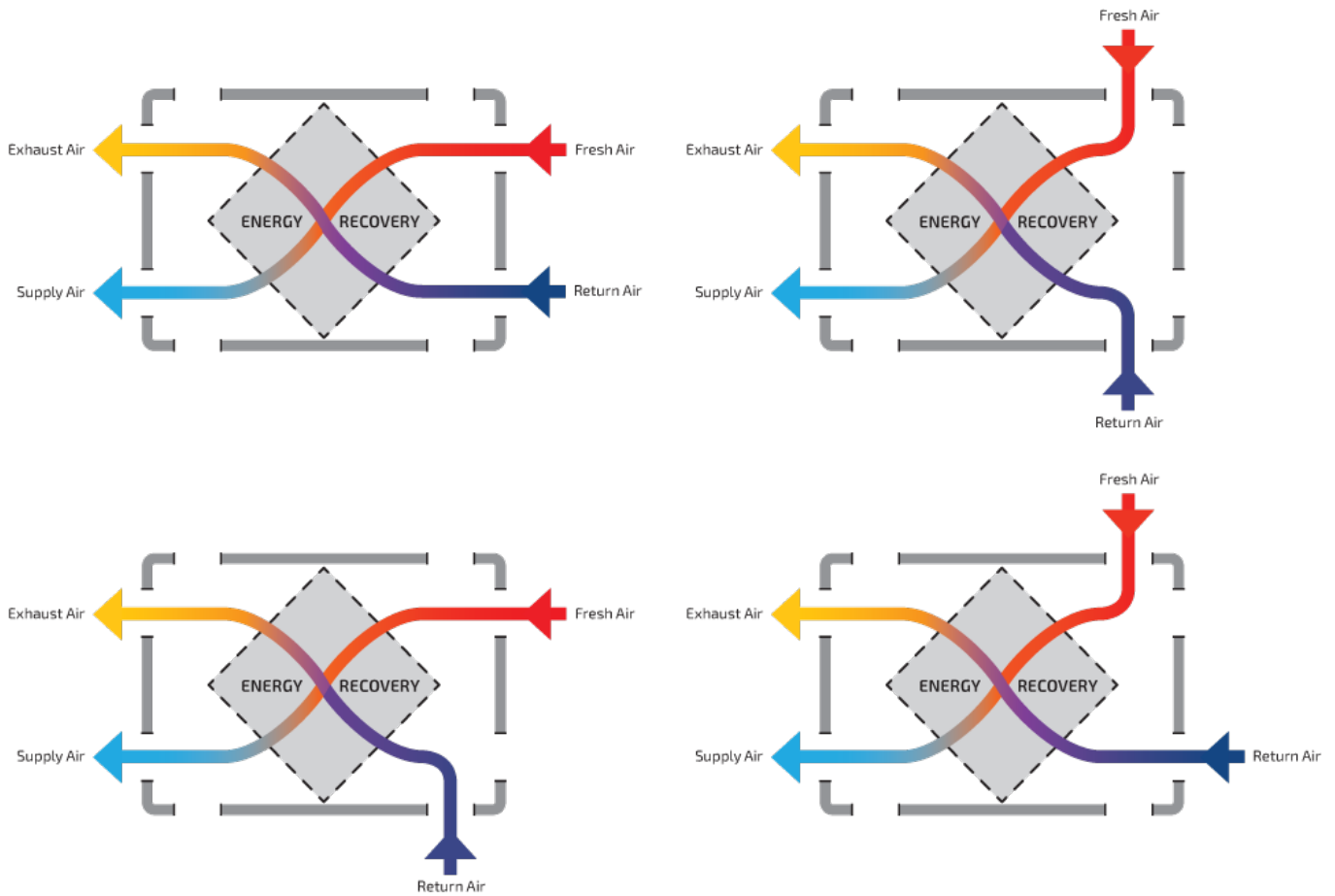

RETURN AIR: Air that is drawn from conditioned areas.

EXHAUST AIR: Ducted to outside the building or into the roof space if adequate ventilation to the outside air is available.

FRESH AIR: Use a fresh air cowl or grill to introduce fresh air.

SUPPLY AIR: Connect to the airconditioning system or directly into the conditioned area.

