

AIR HANDLING UNIT



WITH CHILLED/HOT WATER COILS

AHU6000P1 Technical Data

Technical Specifications

Nominal Airflow

Supply Air (l/sec)	6000
--------------------	------

Supply Fan

Fan Type	EC Plug Fan
Fan Motor	EC Motor
Motor Power (Watts)	4450
External Static (Pa)	300
Fan Diameter	450
Number of Fans	3

Electrical

*Cable sized to maximum FLA. Data presented for airflow at 6000 L/s

Operating Supply Fan (A)	20.4 - 20.4 - 20.4
Maximum Full Load (A)	22.44 - 22.44 - 22.44
Volt/Phase	415V/3ph
Switchboard	Yes
Circuit Breakers	Yes

Controls

0-10V DC (Fan Control)	Included
24V AC Fan Enable Relay	Included
Fan Fault Signal	Included

Cabinet Construction

Casing	50mm Insulated Panel
Insulation Value	R2.0
Side Access Panels	Included

Filters

Type	Deep Bed Filters F5/F6
Size L x W X D (mm)	610 x 610 x 380
Number of Filters	6
Size L x W X D (mm)	610 x 305 x 380
Number of Filters	2
Prefilters	Optional

Chilled Water Coil

if required (Nom.rating)

Total Capacity (Kw)	Customised to suit
Size FL x FH (mm)	2100 x 1143
Water In (°C)/ Water Out (°C)	Customised to suit
Coil Coating	Epoxy Coated
Face Velocity (m/sec)	2.49
Stainless Steel Drain Tray	Included

Hot Water Coil

if required (Nom.rating)

Total Capacity (Kw)	Customised to suit
Size FL x FH (mm)	2100 x 1143
Water In (°C)/ Water Out (°C)	Customised to suit
Coil Coating	Epoxy Coated
Face Velocity (m/sec)	2.49

Options

75mm Panel Casing	Available
Corrosion Resistant Lining	Available
Metu Duct Frames	Available

AIR HANDLING UNIT

With Chilled/Hot Water Coils – AHU6000P1 Technical Data



Technical Drawings – AHU6000P1

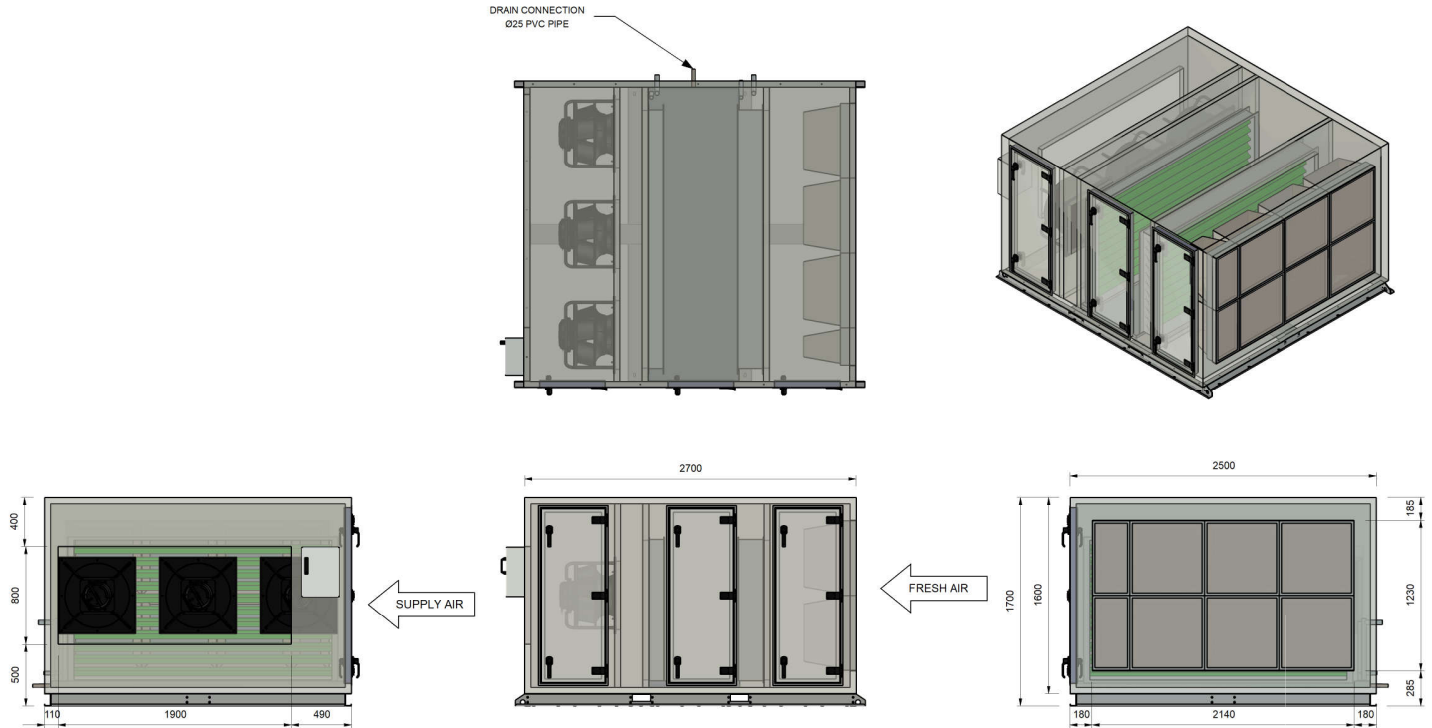

Dimension	
Height (mm)	1700
Width (mm)	2500
Length (mm)	2700
Weight (Kg)	1215
Access Clearance (mm)	1200 (Controls & Filter Access)
Access Clearance (mm)	300

Duct Sizes	
Fresh Air (mm)	2140x1230
Supply Air (mm)	1900 x 800

Fan Performance Data

*Duty point – 6000 L/s at 300 Pa External Static Pressure

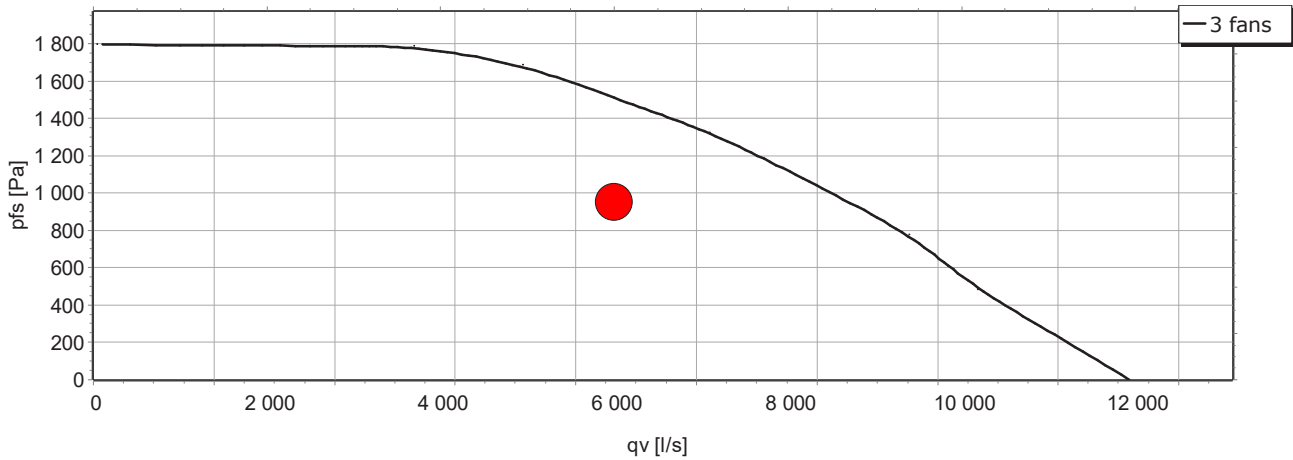

Sound Power Levels

*Sound power levels at 300 Pa External Static Pressure and 6000 L/s Total Air Volume

Inlet Rating dB (A)		Outlet Rating dB (A)	
63 Hz	81.0	63 Hz	82.7
125 Hz	82.5	125 Hz	84.3
250 Hz	82.9	250 Hz	83.6
500 Hz	80.1	500 Hz	85.4
1 K Hz	78.3	1K Hz	85.7
2K Hz	77.0	2K Hz	81.2
4K Hz	79.2	4K Hz	82.7
8K Hz	71.3	8K Hz	76.5
LwA	85.2	LwA	91.4

Wiring Diagram

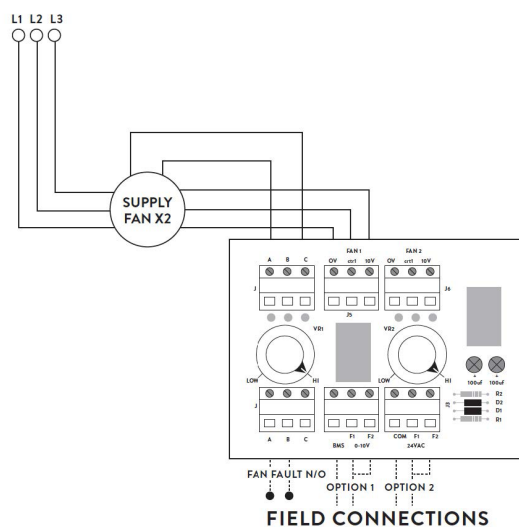

OPTION 1
0-10V DC CONTROL VIA CONNECTION TO BMS

OPTION 2
24V AC ENABLE REGULATE FAN SPEED VIA POTS

Do not turn main power on/off to enable/disable the unit operation. This must be done through the control circuit.

