

# AIR HANDLING UNIT



## WITH CHILLED/HOT WATER COILS

### AHU3500P1 Technical Data

#### Technical Specifications

##### Nominal Airflow

Supply Air (l/sec)	3500
--------------------	------

##### Supply Fan

Fan Type	EC Plug Fan
Fan Motor	EC Motor
Motor Power (Watts)	4450
External Static (Pa)	300
Fan Diameter	450
Number of Fans	2

##### Electrical

\*Cable sized to maximum FLA.  
Data presented for airflow at  
3500 L/s

Operating Supply Fan (A)	13.6 - 13.6 - 13.6
Maximum Full Load (A)	15.0 - 15.0 - 15.0
Volt/Phase	415V/3ph
Switchboard	Yes
Circuit Breakers	Yes

##### Controls

0-10V DC (Fan Control)	Included
24V AC Fan Enable Relay	Included
Fan Fault Signal	Included

##### Cabinet Construction

Casing	50mm Insulated Panel
Insulation Value	R2.0
Side Access Panels	Included

##### Filters

Type	Deep Bed Filters F5/F6
Size L x W x D (mm)	610 x 610 x 380
Number of Filters	4
Prefilters	Optional

##### Chilled Water Coil

if required (Nom.rating)

Total Capacity (Kw)	Customised to suit
Size FL x FH (mm)	1400 x 1016
Water In (°C)/ Water Out (°C)	Customised to suit
Coil Coating	Epoxy Coated
Face Velocity (m/sec)	2.46
Stainless Steel Drain Tray	Included

##### Hot Water Coil

if required (Nom.rating)

Total Capacity (Kw)	Customised to suit
Size FL x FH (mm)	1400 x 1016
Water In (°C)/ Water Out (°C)	Customised to suit
Coil Coating	Epoxy Coated
Face Velocity (m/sec)	2.46

##### Options

75mm Panel Casing	Available
Corrosion Resistant Lining	Available
Metu Duct Frames	Available

# AIR HANDLING UNIT

With Chilled/Hot Water Coils – AHU3500P1 Technical Data



## Technical Drawings – AHU3500P1

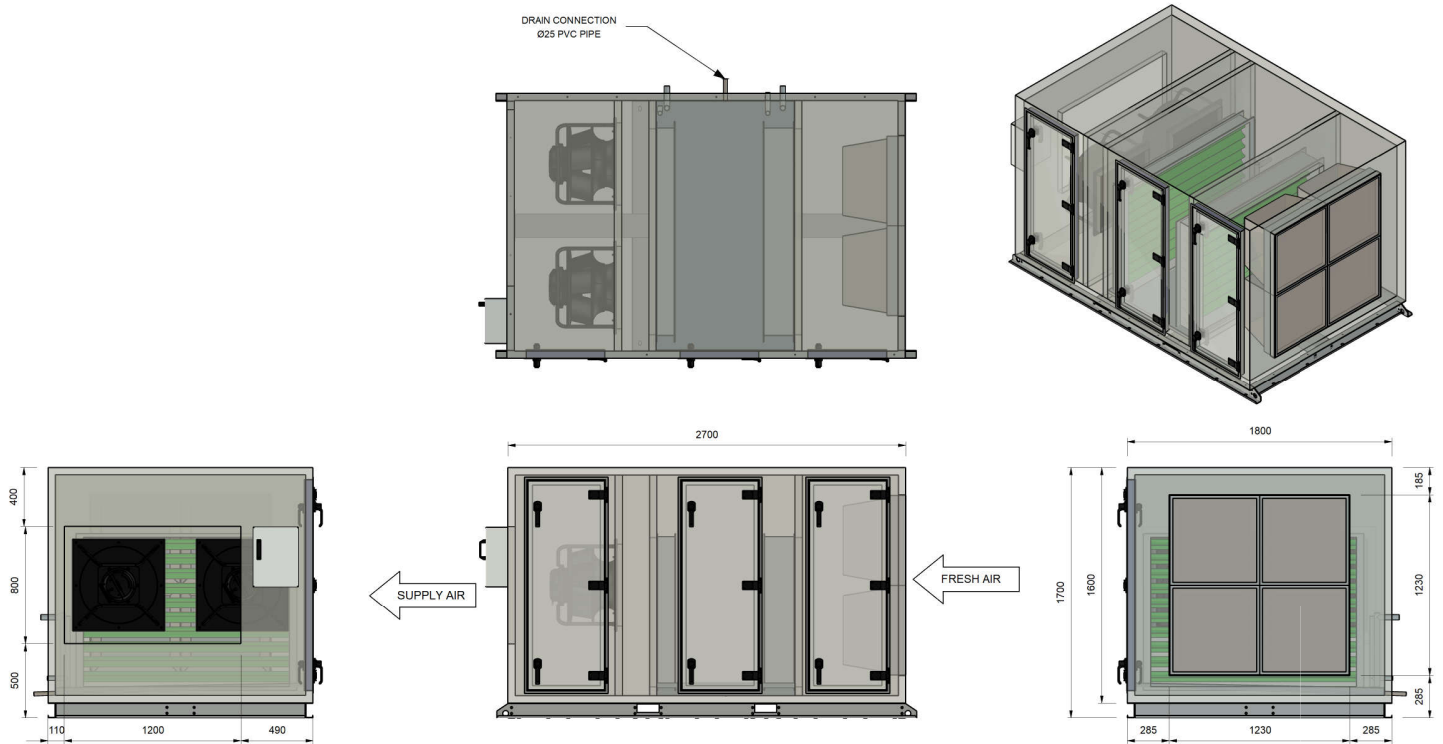

Dimension	
Height (mm)	1700
Width (mm)	1800
Length (mm)	2700
Weight (Kg)	935
Access Clearance (mm)	1200 (Controls & Filter Access)
Access Clearance (mm)	300

Duct Sizes	
Fresh Air (mm)	1230 x 1230
Supply Air (mm)	1200 x 800

## Fan Performance Data

\*Duty point - 3500 L/s at 300 Pa External Static Pressure

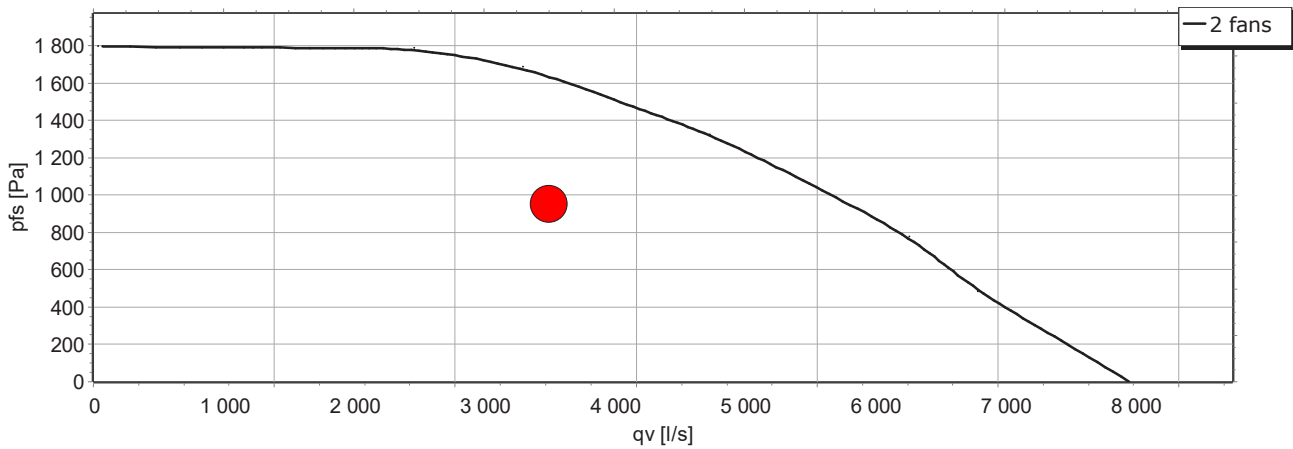

## Sound Power Levels

\*Sound power levels at 300 Pa External Static Pressure and 3500 L/s Total Air Volume

Inlet Rating dB (A)		Outlet Rating dB (A)	
63 Hz	78.8	63 Hz	80.3
125 Hz	82.7	125 Hz	83.7
250 Hz	80.1	250 Hz	81.6
500 Hz	77.9	500 Hz	83.2
1 K Hz	76.1	1K Hz	83.3
2K Hz	74.6	2K Hz	73.2
4K Hz	73.9	4K Hz	78.7
8K Hz	68.3	8K Hz	73.8
LwA	82.2	LwA	88.6

## Wiring Diagram

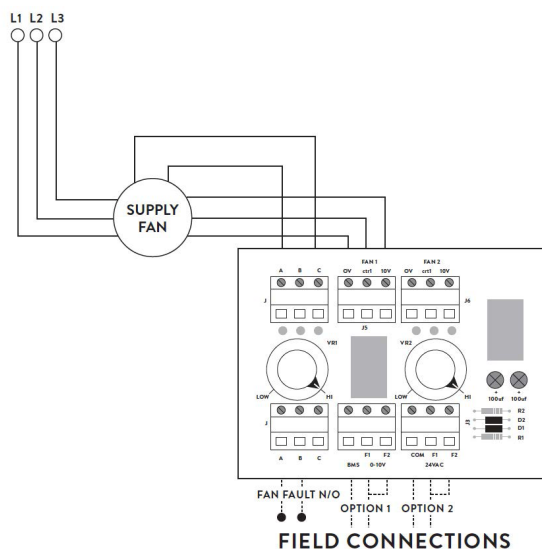

### OPTION 1

0-10V DC CONTROL VIA CONNECTION TO BMS

### OPTION 2

24V AC ENABLE REGULATE FAN SPEED VIA POTS

Do not turn main power on/off to enable/disable the unit operation. This must be done through the control circuit.

