

ROTARY HEAT WHEEL ERV

External Mount Unit

REM4000P3 Technical Data

Technical Specifications

Nominal Airflow

Supply Air (l/sec)	4000
Exhaust Air (l/sec)	4000
Return Air (l/sec)	4000
Fresh Air (l/sec)	4000

Supply Fan

Fan Type	EC Plug Fan
Motor Power (Watts)	4500
External Static (Pa)	250
Fan Diameter	450
Number of Fans	2

Exhaust Fan

Fan Type	EC Plug
Motor Power (Watts)	4500
External Static (Pa)	250
Fan Diameter	450
Number of Fans	2

Electrical

Supply Fan FLA (A)	13.6 - 13.6 - 13.6
Exhaust Fan FLA (A)	13.6 - 13.6 - 13.6
Rotary Wheel (A)	0.7 - 0.7 - 0.7
Nominal Run Current (A)	27.9 - 27.9 - 27.9
Volt/Phase	415V/3ph
Switchboard	Yes
Circuit Breakers	Yes

Controls

0-10V DC (Fan Control)	Included
24V AC Enable Heat Wheel	Included
Heat Wheel VSD	Included

Rotary Heat Wheel

*Rated at standard conditions of Summer 35.5° db/40% RH Winter 3° db/68%RH

Sensible Heat Wheel	Standard
Enthalpy Heat Wheel	Available
Wheel Diameter (mm)	2340
Efficiency %	84.1
Size L x W x D (mm)	2250 x 2250 x 440
Media Face Velocity (m/sec)	2.12
Pressure Drop (Pa)	165
Kw Recovered (Cooling)*	68.75
Kw Recovered (Heating)*	115.35

Cabinet Construction

Casing	50mm Panel
Insulation Value	R2.0
Side Access Panels	Included

Filters

Type	Deep Bed Filters F6
Size L x W x D (mm)	610 x 610 x 380
Number of Filters	8
Size L x W x D (mm)	610 x 305 x 380
Number of Filters	8

Options

Chilled Water/ Hot Water Coil	Available (Model REC4000)
Corrosion Resistant Lining	Available
Stainless Steel Drain Tray	Available

ROTARY HEAT WHEEL - ERV

External Mount Unit – REM4000P3 Technical Data

Technical Drawings – REM4000P3

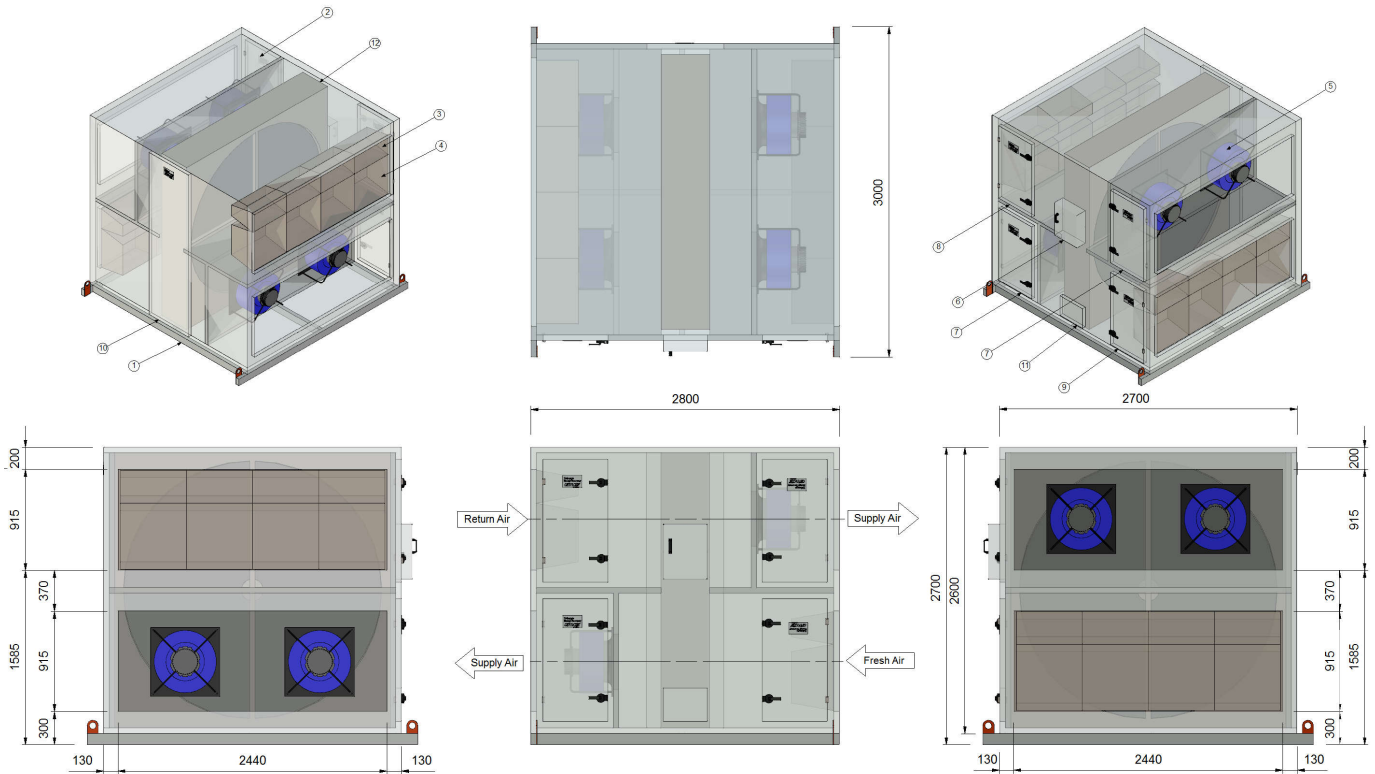

Dimension	
Height (mm)	2700
Width (mm)	2700
Length (mm)	2800
Weight (Kg)	1680
Access Clearance (mm)	800 (Controls & Filter Access)
Access Clearance (mm)	300

Duct Sizes	
Exhaust Air (mm)	2440 x 915
Return Air (mm)	2440 x 915
Supply Air (mm)	2440 x 915
Fresh Air (mm)	2440 x 915

Fan Performance Data

*Duty point - 4000 L/s at 600 Pa Total Static Pressure (250Pa External Static Pressure)

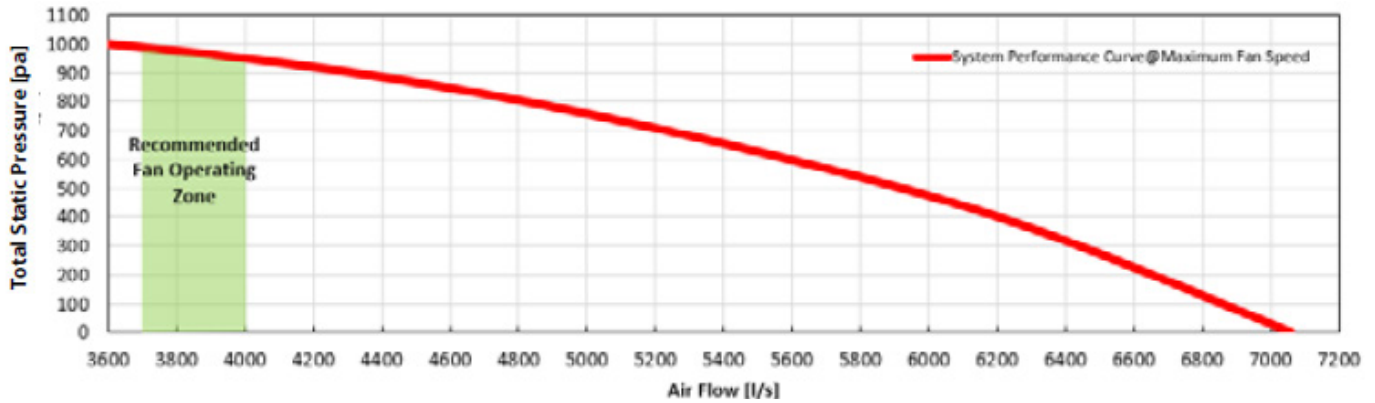

Sound Power Levels

*Sound power levels at 550 Pa Total Static Pressure and 4000 L/s Total Air Volume

Inlet Rating dB (A)		Outlet Rating dB (A)	
63 Hz	69.2	63 Hz	70.8
125 Hz	73.8	125 Hz	75.3
250 Hz	75.8	250 Hz	76.4
500 Hz	72.6	500 Hz	78
1 K Hz	70.7	1K Hz	79.4
2K Hz	70.4	2K Hz	76.3
4K Hz	68.3	4K Hz	72.9
8K Hz	64	8K Hz	67.5
LwA	77.1	LwA	83.2

Wiring Diagram

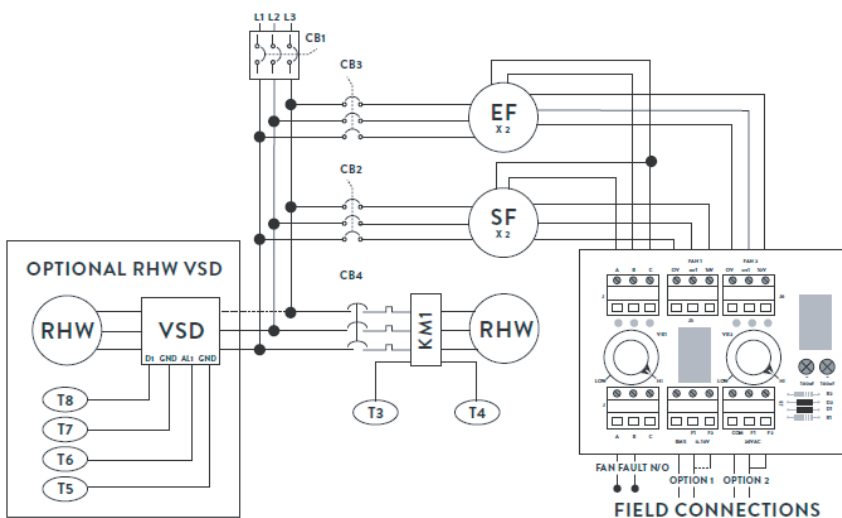

Option 1

0-10V DC CONTROL VIA CONNECTION TO BMS

Option 2

24V AC ENABLE REGULATE FAN SPEED VIA POTS

Do not turn main power on/off to enable/disable the unit operation. This must be done through the control circuit.

